

Re-examination of the Experimental Evidence for a Nonzero Aether Drift

Part 2: Rotational and post-1930 linear experiments

by

Paulo N. Correa, Alexandra N. Correa, David Pratt, Malgosia Askanas

CONTENTS

1. INTRODUCTION	1
2. KENNEDY-THORNDIKE EXPERIMENT	3
3. IS-TYPE DOPPLER SHIFT EXPERIMENTS	3
3.1 IS experiment.....	3
3.2 Non-storage-ring experiments.....	5
3.3 Storage-ring experiments.....	6
4. SILVERTOOTH EXPERIMENT.....	6
5. MÚNERA'S EXPERIMENT	8
6. GALAEV'S EXPERIMENTS	9
7. ROTATIONAL EXPERIMENTS.....	10
7.1 Sagnac experiment	10
7.2 Michelson-Gale experiment.....	13
REFERENCES	15

1. INTRODUCTION

After the 1930's, a consensus formed in the world of physics that accepted the null result of the Michelson-Morley (MM) experiment. Since the null result was required by Special Relativity (SR), acceptance of the former seemingly justified SR's rise to dominance. This resulted in what became generally accepted as the postulate of Lorentz invariance, which states that the laws of physics are the same for all reference frames in nonaccelerated motion. From 1930 onward, optical experiments (of the MM and Kennedy-Thorndike (KT) types) were believed to measure the null effect attributed to transverse and longitudinal Lorentz contractions (so-called isotropy of space), whereas the frequency-shift (Ives-Stilwell (IS)) type experiments were believed to show a positive effect that was interpreted by both SR and Lorentz-Larmor Relativity (LLR) in terms of the rate of change of a moving clock (so-called isotropy of time).

This way of framing the significance of these types of experiments is a gross and aprioristic epistemological error. But it is an error that has sustained the shift from an epoch in which SR achieved complete domination, to one where, while still dominant, it was forced to adapt to the notion that it might after all be possible to detect light-speed variance caused by “absolute” (“net”) motion with respect to the electromagnetic frame of the cosmic microwave background radiation (mCMBR). Indeed, present parametrizations of the various types of experiments (MM, KT and IS) resort to test theories (not SR) – such as the Robertson, Mansouri and Sexl (RMS) theory (Robertson, 1949; Mansouri & Sexl, 1977) – where the postulates of SR are abandoned in favor of an arbitrary choice of a preferred reference frame, generally considered to be that of the mCMBR. Thus, modern IS-type experiments limit themselves to placing constraints on any Lorentz violations that might stem from the existence of a preferred reference frame.

While the RMS framework is restricted to Special Relativity, the Standard Model Extension includes General Relativity and the Standard Model of particle physics, and investigates possible spontaneous breaking of both Lorentz invariance and charge, parity, and time reversal (CPT) symmetry (Colladay & Kostelecký, 1997, 1998; Kostelecký, 2004).

Historically, the dominant relativistic interpretation of the IS experiment of 1938 (Ives & Stilwell, 1938) opened up a new approach that re-contextualized both interferometric experiments and the interpretation of their results. It was no longer possible to regard these experiments as anything other than particular measures of the exactitude of the Lorentz transformations for length and time. If there were any violations (such as, for example, string theory has proposed), one would find them by progressively placing more stringent experimental brackets on the value of the invariance. But, axiomatically, interferometric experiments would no longer be able to challenge the generalized relativistic interpretation. Optical experimental designs still followed the MM and KT setup, in that they still employed closed optical circuits and detected changes in the round-trip velocity of light. But the experiments now measured frequency shifts, rather than fringe shifts. The pivotal experiment that breaks with this mold is also the IS experiment. Here, emission of light from hydrogen canal rays (positively charged hydrogen atoms) in directions transverse to the motion of the rays permitted the first accurate determination of the frequency shift predicted by the second-order transverse Doppler effect. Even though this experiment caused a sensation at the time – as the observed frequency shift was hailed as proof of time dilation – the authors refused to see the results as an endorsement of SR. In fact, Ives interpreted the results to suggest, but without proof, that LLR was better suited to explain the 1938 IS results.

Later IS-type experiments would employ high-precision masers, lasers and highly homogenous heavy-ion beams, culminating in the modern ring-storage experiments. We will address these experiments in section 3. They have all reported null results and an increasingly more accurate determination of the second-order light Doppler effect.

It is important, at this point, to reflect upon an often neglected detail in the history of measurement of light speed and its variance. The light Doppler effect can be predicted entirely on the basis of the law of the geometric-mean composition of velocities of source and receiver. Of the relativistic theories, only SR gives a result that fully coincides with that of the velocity

composition law. But any demonstration of the correctness of the law – or, more correctly, any more exacting measurement of the transverse or longitudinal Doppler effects – cannot be construed as an unequivocal proof of SR. The 1938 IS experiment suggested that the transverse Doppler effect was a reality, but lacked the resolution needed to distinguish between the two relativistic theories, SR and LLR. However, the existence of a second-order transverse Doppler shift consistent with the law of velocity composition could never validate by itself the assumption that moving clocks change their counting rate. This is the epistemological fallacy that underlay the assumptions made by Ives and Stilwell in their 1938 experiment.

As noted in [Part 1](#), Aetherometry proposes a theory of photon emission and of the light Doppler effect that is based solely on a consistent application of the law of geometric-mean composition of velocities, and its model more closely matches the results of the IS experiment without invoking time dilation or length contraction (Correa & Correa, 2008; Correa et al., 2008).

2. KENNEDY-THORNDIKE EXPERIMENT

In 1932, Kennedy and Thorndike conducted an experiment using an interferometer similar to Michelson's except that it had unequal-length, non-perpendicular arms and a highly sophisticated light source, the whole apparatus being enclosed in a high-vacuum chamber (Kennedy & Thorndike, 1932). They reported a daily "aether-drift" effect of 24 ± 19 km/s, and a long-period effect of 15 ± 4 km/s at 123° to the former, giving an overall result of 10 km/s ± 10 km/s. They concluded: "In view of relative velocities amounting to thousands of kilometers per second known to exist among the nebulae, this can scarcely be regarded as other than a clear null result." The arms of the interferometer were assumed to undergo length contraction, and any fringe shift was interpreted as a measure of time dilation with respect to the difference of apparent travel times along the two shortened arms. Given that the resolution of their device was worse than that of the MM interferometer (with standard errors of the mean on the order of 3 km/s; see [Part 1](#)), their result could hardly be construed as a proof of SR. It was, however, used to counteract claims – such as Miller's – of an aether drift of around 10 km/s.

Gurzadyan & Margaryan (2018) report a high-precision KT test that set a limit of $7 \cdot 10^{-12}$ on one-way light speed invariance with respect to the velocity of the observer (apparatus).

3. IS-TYPE DOPPLER SHIFT EXPERIMENTS

3.1 IS experiment

In 1887, even before the MM experiment was performed, W. Voigt indicated that it would be unable to detect the earth's absolute velocity due to a nonclassical Doppler effect (usually inappropriately referred to as the 'relativistic' Doppler effect); he obtained the so-called Lorentz transformation 15 years before Poincaré (Wesley, 1987b). In 1938, Ives and Stilwell published the results of an elegant experiment that avoided the difficulties introduced by MM-type and KT-type experiments by trying to observe light emitted transversely to the direction of motion of the

atoms, and obtained a result strictly complementary to the null result of MM-type experiments (Ives & Stilwell, 1938). The IS experiment measured the Doppler shift of the light emitted forward and backward (direct and reflected Doppler lines) from hydrogen canal rays, i.e. in parallel and antiparallel directions to their motion. The result of the IS experiment was the final demise of classical physics, as the results were instead compatible with the Lorentz invariance of SR and LLR.

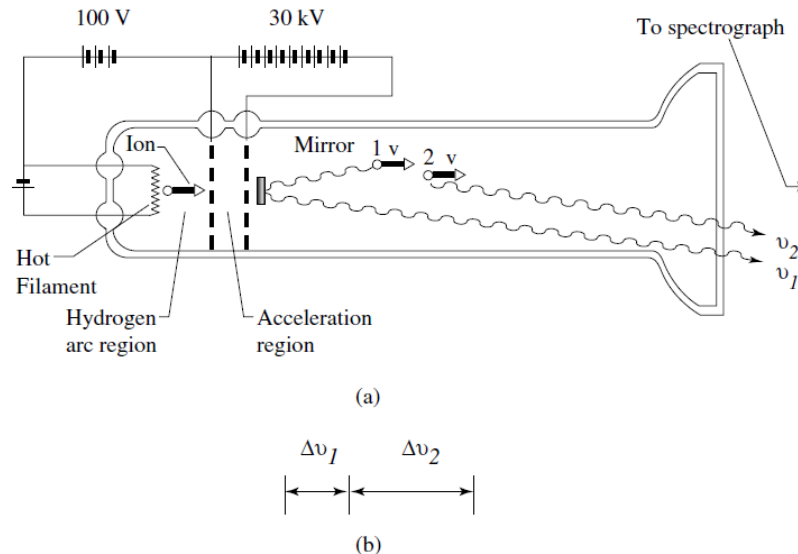

Figure 1 The Ives & Stilwell apparatus (after Halliday et al., 1992). (a) Schematic of the canal-ray tube. (b) Illustration of the Doppler shifts measured by the experiment. (Correa et al., 2008, fig. 1)

Unlike MM- and KT-type experiments, which involve two-way light travel, the IS experiment and some of its various successors involve one-way light travel. They have this in common with the Sagnac, Michelson-Gale, and Silvertooth experiments (see below).

Three velocity-dependent test functions have been proposed in so-called RMS theory to parametrize time dilation and the complementary Lorentz contraction in both longitudinal and transverse directions: $a(v^2)$, $b(v^2)$ and $d(v^2)$ (Rheinhardt et al., 2007). By expanding these functions, which are referenced to a hypothetical preferred frame, $a(v^2)$ becomes defined as an arbitrary function of α and the postulated coefficient ϕ , per:

$$a(v^2) = \{1 + [\alpha(v^2/c^2)] + [\phi(c^{-4})]\}$$

so that α is treated as the test parameter that was supposedly probed by IS-type experiments on time dilation. Similar expansion expressions address other test parameters, β and δ , all of which are taken as being unity in SR (Lorentz invariance). According to RMS theory, MM-type experiments test the absolute difference between β and δ parameters and KT-type experiments test the absolute difference between α and β . In the rather arbitrary RMS theory, parameter $b(v^2)$ is taken to measure the longitudinal (an)isotropy, whereas the parameter $d(v^2)$ is taken to measure the transverse (an)isotropy.

3.2 Non-storage-ring experiments

Post-IS experiments focused on determining the parameter $\Delta c/c$ – where Δc is the deviation from c of the observed velocity of a light signal traveling one way along a particular spatial direction – to supposedly measure spatial Lorentz contraction and put a limit on its deemed violations.

Earlier experiments measured the difference in the relative frequencies of two cavity-stabilized lasers upon local rotations of the apparatus (Brillet & Hall, 1979) or under the earth's rotation (Müller et al., 2003). Brillet & Hall failed to detect any variation in light velocity down to a limit of less than 5×10^{-7} m/s for the round-trip anisotropy, or $(5 \times 10^{-7}) \cdot c = 150$ m/s for the more usual one-way anisotropy. They actually claimed that they had found a fractional length change on the order of $\Delta L/L = (1.5 \pm 2.5) \times 10^{-15}$, corresponding to a 17 Hz residual signal. Brillet later claimed this was an “off-vertical” error that likely introduced distortion between the parallel and transverse directions. Marmet (2005) claimed that Brillet & Hall ignored the needed change of path in the transverse direction, “due to an angle that makes the light path $(1/\cos a)$ times longer ... when it is moving sideways” (a is the angle in “Galilean space” between what Marmet calls the parallel and the transverse directions). Aspden (1981) provided a different explanation – that Brillet & Hall had unwittingly detected the earth's speed of rotation using essentially the Sagnac effect (more on this below).

Müller et al. (2003) put a limit on light anisotropy of $(8 \pm 5) \times 10^{-7}$ m/s, corresponding to $\Delta c/c = (2.6 \pm 1.7) \times 10^{-15}$. Expressed with reference to the RMS test theory, it implied a possible isotropy violation of $|\beta - \delta| - 0.5 = (-2.2 \pm 1.5) \times 10^{-9}$.

Jaseja et al. (1964) mounted two He-Ne microwave masers perpendicularly to each other on a table isolated from acoustical vibrations, and observed the relative frequency shifts between them as the table was rotated through 90° . Rotation produced repeatable variations in the frequency difference of about 275 kHz, equivalent to an aether drift “somewhat less than that attributable to the earth's orbital velocity on the simple ether theory”, but this was presumed to be a systematic error arising from “magnetostriction in the Invar spacers due to the earth's magnetic field”. They concluded that “the amplitude of the sinusoidal variation in the frequency shift due to an ‘ether drift’ ... is not greater than 3 kilocycles/sec”, and thus not larger than an anisotropy of 1/1000 of the small fractional term $(v/c)^2$ associated with the earth's orbital velocity, i.e. less than 30 m/s.

Twenty-five years later, Krisher et al. (1990) compared the phases of two hydrogen masers separated by a distance of 21 km and connected via an ultrastable fiber-optics link of the NASA deep-space network, and obtained a limit of $\Delta c/c < 3.5 \times 10^{-7}$. This corresponded to a transverse anisotropy not greater than $\Delta c = 105$ m/s. Riis et al. (1988) tested the variation with spatial direction of the first-order Doppler shift of light emitted by an atomic beam and obtained a limit of $\Delta c/c = 3 \times 10^{-9}$, placing a much stricter limit of $\Delta c = 0.9$ m/s on any possible transverse anisotropy. Since both these experiments relied on the rotation of the earth to change the signal transmission direction, they appeared to be sensitive only to a component of the direction of Δc that lies on the equatorial plane. Using the clocks on board the Global Positioning System

(GPS) satellites (providing baselines of at least 20,000 km), Wolf & Petit (1997) obtained a limit of $\Delta c/c < 5 \cdot 10^{-9}$ when considering all spatial directions and $\Delta c/c < 2 \cdot 10^{-9}$ for the component in the equatorial plane.

From these experiments, the inferred upper limit of possible violation for the RMS parameter α was approximately 10^{-6} .

Nagel et al. (2015) performed a modern MM experiment with two orthogonally aligned stable microwave oscillators. In addition to the rotation transformations provided by earth's daily and annual cycles, the apparatus was continuously rotated with a 100 s period on a tilt-controlled air-bearing turntable. Using data of the beat note frequency between the two oscillators recorded over the course of a year, they found no significant variations in the speed of light, and constrained violations of Lorentz invariance to $< 10^{-18}$, the most precise measurement to date for electromagnetic cavity experiments.

3.3 Storage-ring experiments

Another class of experiments have employed the hyperfine transitions of ${}^7\text{Li}$ (Riis et al., 1994; Rong et al., 1998) to measure – with high-precision laser saturation spectroscopy – the transition frequencies for ${}^7\text{Li}$ ions accelerated to different velocities in storage rings (Saathof et al., 2003; Rheinhardt et al., 2007). An upper bound of $< 8.4 \cdot 10^{-8}$ has now been placed on test parameter α by means of what is, essentially, a measurement of Doppler-shifted emissions – from atomic beams subject only to minimized inertial collisions – of light signals (hyperfine transitions) traveling one way along a particular spatial direction.

4. SILVERTOOTH EXPERIMENT

MM-type experiments are designed to measure a second-order effect, i.e. one proportional to $(v/c)^2$, since the light rays are reflected back on themselves. Several scientists have argued that two-way light transmission fails to detect an aether drift because 180° light reflection nullifies any change in light speed. One such scientist was E.W. Silvertooth, one of the pioneers of the standing-wave interferometer, who devised a different experimental design involving one-way light travel to permit a first-order determination of the earth's "absolute" velocity (Silvertooth, 1987, 1989; Silvertooth & Whitney, 1992).

Laser light was split into two beams that were sent in opposite directions around a rectangular path. Part of Silvertooth's experimental setup was equivalent to one of the arms of the MM interferometer. He reported that light traveling out and back along this arm was insensitive to the "absolute" velocity of the laboratory – consistent with a null result in the MM experiment. In another arm of the device one-way light travel took place. Here, a special detector scanned through the standing wave, and detected the position of the nodes with high precision. The spacing between the nodes varied with orientation of the apparatus and with the time of day, meaning that the wavelength of light changed depending on the direction the laser beam pointed in space.

Silvertooth (1989) stated: “The axis of the photodetector making the linear scan through the standing wave was directed towards the constellation Leo when the maximum value of v was registered. Six hours before and after the event the displacement of the detector revealed no phase changes, meaning that the photodetector was being displaced perpendicular to its motion relative to the ether.”

He concluded that the absolute motion of the earth and solar system was 378 km/s in the direction of Leo. He reported that he had repeated the experiment in a variety of configurations over the course of several years, with results ranging within $\pm 5\%$ of this velocity. However, no detailed experimental data was ever published. Wesley (1987a) reported that the final result was: $v = 378 \pm 8$ km/s towards RA = 11 ± 1 h and Dec = $-20 \pm 2^\circ$ (an apex located in the Crater constellation below Leo), in reasonable agreement with the values derived from the mCMBR dipole anisotropy: $v = 369.82 \pm 0.11$ km/s, RA = 11.1961 ± 0.0005 h, Dec = $-6.944 \pm 0.007^\circ$ (Planck Collaboration, 2019).

Tom Roberts, a proponent of orthodox relativity theory, has criticized the Silvertooth experiments for not considering the entire light path: “Their analysis considered only the light path from the last mirrors before the sensor. In their model, the anisotropy in the 1-way speed of light between those mirrors is exactly canceled by the timing anisotropy induced by the light paths from laser to those mirrors” (email, 2008). The assumption that length contraction/time dilation will cancel each other out also characterizes General Relativity’s early and unsuccessful efforts to explain the Sagnac experiment (Correa & Correa, 2008). Roberts (2007) also objected that “the apparatus is excessively finicky – an attempt to repeat the measurement using his apparatus failed to see any effect at all”. Since this statement is based on hearsay, it cannot be used to impugn either Silvertooth’s technical ability or the accuracy of his results.

Marinov performed a simplified repetition of the Silvertooth experiment and claimed to have obtained a comparable result: $v = 386 \pm 38$ km/s, RA = 12.5 ± 0.5 h, Dec = $-22 \pm 6^\circ$. He reported similar results with his first-order coupled-mirrors experiment and toothed wheels experiment (Marinov 1980, 1987). Roberts (2007) makes the following criticisms of his work:

Marinov thinks his rotating mirrors and apertures provide an “absolute synchronization” which can be used to measure the one-way speed of light; this is not so, and is a major conceptual error in his design: they merely provide synchronization in the rest frame of his lab. He is also conspicuously bad about ignoring errors and resolutions, to the point of being ridiculous. Simple estimates based on his apertures and rotation rates show that his apparatus is incapable of measuring what he claims, by a factor of 1,000 or more. His apparatus inherently averages over several microseconds (or more), and he completely ignores this basic fact and claims to be measuring the speed of light over a distance of 1.4 meters (!). And he does not bother to monitor various environmental factors (temperature, humidity, barometric pressure) that could easily induce the variations he observes. There is no reason to believe his experiments have any value at all.

The issues raised by the Silvertooth experiment will be further addressed in Part 3.

5. MÚNERA'S EXPERIMENT

Hector Múnera ran experiments using a stationary Michelson-Morley interferometer at the International Center for Physics (CIF) laboratory in Bogotá (Colombia) from January 2003 to February 2005 (Múnera, 2006, 2017; Múnera et al., 2007, 2009). The interferometer, with arms measuring 2.044 m, was mounted on a reinforced concrete anti-vibration table 4.48 m long, 2.57 m wide, and 0.32 m thick, weighing 13 metric tons. The table was placed in a ground-floor room with dark walls and polystyrene thermal insulation in the former windows. The optical path was enclosed inside plastic tubing (approximately 3 cm in diameter), surrounded by polystyrene insulation (approximately 5 cm thick). The beam splitter was also covered with thermal insulation. The two thermal sensors showed that temperature variations were usually no more than $\pm 0.2^\circ\text{C}$, and occasionally $\pm 0.4^\circ\text{C}$.

Whereas all the earlier MM-type experiments only measured fringe shifts in fractions of a fringe, with anything greater being attributed to thermal artefacts, Múnera's setup was designed to allow far larger fringe shifts to be measured. The automatic data-gathering system (with video camera) made readings every 0.25° , at one-minute intervals. The room was not environmentally controlled, but temperature and humidity were logged every 3 to 5 minutes. The measured fringe shifts were strongly correlated with temperature, humidity and pressure; after corrections had been made, the maximum fringe shift was reduced from about 24 to 2. The fringe shifts showed various periodicities, including a sidereal day. Roberts (2007) argues that no firm conclusions can be drawn from the experiment due to inadequate environmental monitoring and control.

Efforts to calculate the solar velocity that best fitted the data led to two solutions, one in the northern celestial hemisphere and one in the southern. The southern solution is: $v = 500 \text{ km/s}$, $RA = 16.67\text{h}$, $Dec = -75^\circ$. This produces an average correlation of 55% (standard deviation 0.29) between predicted and observed fringe shifts. Since the center of our galaxy is located at $RA = 17.76\text{h}$, $Dec = -29.0^\circ$, Múnera argues that this solar velocity is consistent with a rotational motion of the sun around the center of the galaxy plus a free fall of the solar system towards the galactic center.

The (preferred) northern solution is: $v = 365 \text{ km/s}$, $RA = 5.4\text{h}$, $Dec = +79$. The average correlation is then around 70%, and the standard deviation is less than half the value obtained for the southern solution. The velocity of 365 km/s is close to the velocity determined relative to the mCBR ($\sim 370 \text{ km/s}$), but the northern apex is 96° from the mCBR-derived apex, while the southern apex is 81° from the mCBR apex. Neither solution matches this or any other observed cosmic motion. However, Múnera et al. (2009) state that it is a "remarkable coincidence" that optical measurements seem to concentrate on a plane passing through $RA = 5\text{h}$ and 17h , while mCBR-type measurements are in a direction almost perpendicular to this plane. Múnera et al. claim that all MM-type experiments have produced nonzero results, but overlook the fact that, as demonstrated in [Part 1](#) of this article, a result may be nonzero but also nonsignificant and therefore null.

6. GALAEV'S EXPERIMENTS

Yuri Galaev conducted a first-order radio-wave interferometer experiment from August 1998 to August 1999 (Galaev, 2001). It was performed an average of 42 m above the earth's surface and reportedly detected a drift of 1,414 m/s. Subsequently, Galaev (2002) conducted a first-order optical interferometer experiment from August 2001 to January 2002, involving 2,322 readings. He gives the instrument resolution as 26.25 m/s, a doubtful feat. The interferometer was first placed 1.6 m above ground level, in the open air, but shaded by trees, and detected a drift velocity of 205 m/s. It was then placed 4.74 m above ground level, again in the open air, but under an umbrella, and detected a velocity of 435 m/s. In both cases the ground level was about 190 m above sea level. In the winter, the interferometer was moved to a brick building, and located at a height 30 m above ground level (about 130 m above sea level); the results of this experiment were not given.

Galaev (2002) tries to reconcile his experimental results with those of Miller (1926) and Michelson et al. (1929), but in doing so indulges in several distortions. He claims that all these experiments demonstrate that the aether-drift velocity increases consistently with height above the earth's surface, at a rate of 8.6 m/s per meter of altitude. Yet based on his own results at 1.6 and 4.74 m above ground level, the rate would be 73.25 m/s per meter of height. Furthermore, he gives the altitude of his own experiments in terms of height above ground level, but gives those of Miller and Michelson et al. in terms of height above sea level! Only through this sleight of hand can he sustain his claim.

Furthermore, he only takes into consideration two of Miller's results – Cleveland Heights 1905 (which he gives as 3 km/s, ignoring the fact that Miller later corrected the result from 3.9 km/s to 8.7 km/s) and Mt Wilson (~10 km/s) – and ignores all of Miller's other results, along with his analysis of the 1887 MM experiment. As noted in [Part 1](#), Miller came to the conclusion that altitude was *not* a significant factor in the aether-drift velocity that he claimed to have observed. Galaev also claims that Michelson, Pease and Pearson found an aether drift of 6 km/s on Mt Wilson (Michelson et al., 1929). In actual fact, this experiment detected less than 1/50 of the fringe shift corresponding to 300 km/s. This is equivalent to $<42.4 \text{ km/s} (= 300/\sqrt{50})$ – and not to 6 km/s ($= 300/50$) as Galaev mistakenly claims. Since this experiment was performed in a basement, Galaev then “corrects” his erroneous value so that it matches Miller's own result on Mt Wilson!

Galaev (2002) does not present a computation of the velocity of “absolute” motion from his own experimental results, but says that they “do not contradict” Miller's northern apex (he forgets to mention that Miller eventually saw reason to switch to a southern apex). Moreover, Galaev says that in his own experiments the aether-drift azimuth varies symmetrically about the meridian line – something which was definitely *not* the case in Miller's 1925-26 experiments. When comparing his own aether-drift velocity results for August with Miller's, Galaev mentions an unexplained discrepancy of about 2.2 hours (33°) in the position of the minimums. In short, Galaev's claim to have confirmed Miller “down to the details” is patently false. DeMeo (2004), however, uncritically parrots Galaev's claim.

7. ROTATIONAL EXPERIMENTS

7.1 Sagnac experiment

In contrast to the controversy surrounding experiments to detect the solar system's "absolute" translational motion, it is now well established that absolute rotation *can* be detected optically. Georges Sagnac (1913a,b, 1914) showed that if light beams are sent in opposite directions round a rotating platform, the velocity of light is $c - v$ for the beam traveling in the direction of rotation and $c + v$ for the beam traveling in the opposite direction, with v being equal to the linear rotation velocity of the platform. The shape of the circuit and the location of the axis of rotation (at the center of the disk or away from it) made no difference to the result. The most straightforward explanation is that light travels at c relative to the laboratory and not relative to the spinning disk. Sagnac believed that his experiment was consistent with the existence of a static aether and disproved relativity theory.

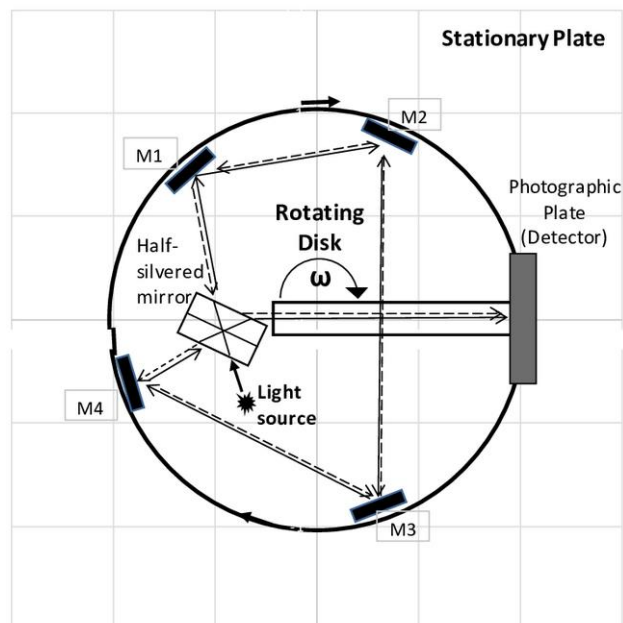

Figure 2 Schematic representation of the Sagnac experiment.

Sagnac placed the light source (a flashlight), the fringe detector (an interferometer) and the photographic recorder all aboard the spinning disk. The fringe shift results from the different times taken by the light signals to traverse the circuit on the disk in opposing directions. The travel-time difference is $\Delta t = 4A\omega/c^2$, where A is the area enclosed by the light path and ω is the angular rotation velocity. If the disk spins counter-clockwise, the detector moves *towards* the clockwise-traveling ray and *away from* the counter-clockwise-traveling ray, with the result that the former travels a shorter distance than the latter.

Beginning in 1937, Dufour & Prunier (1942) repeated the Sagnac experiment, first with the original design and then with modified designs. They observed the same fringe shift regardless of whether the light source and the photographic recorder were both on the spinning disk, or

both fixed in the laboratory frame, and also when one was rotating and the other stationary. If the photographic recorder is in the fixed laboratory, there is a slight Doppler effect because the disk is moving past the viewing lens. Post (1967) found that the effect was too small (v/c smaller than the Sagnac effect) to have any observable effect. He also stated that the time dilation factor predicted by Special Relativity was one order of magnitude smaller than the Doppler correction.

Dufour & Prunier also performed a test in which the light first traversed a path on the spinning disc, was then reflected up to a mirror fixed overhead in the laboratory and traversed a horizontal path, and was finally reflected back down to the disk, where it completed its horizontal trajectory. In this test, the light emitter and the photographic recorder were fixed in the laboratory. Only movements with and against the direction of rotation (i.e. nonradial movements) contributed to the fringe shift.

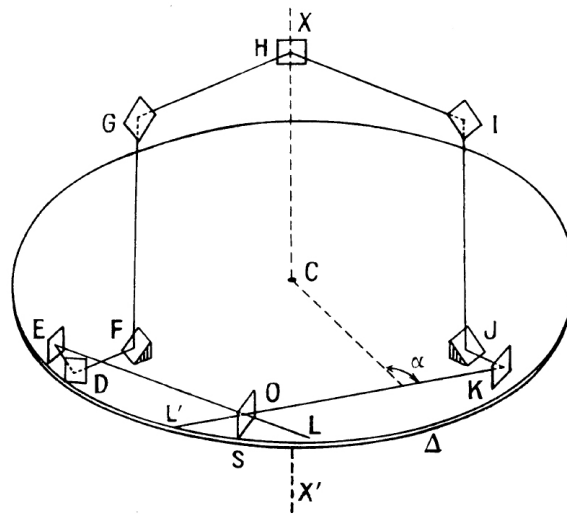

Figure 3 One of Dufour & Prunier's tests. C is the center of the disk. The light source is at L', and the photographic plate at L. (Dufour & Prunier, 1942, fig. 6)

Sagnac-type experiments show that although the light beams are deflected around the circuit by mirrors attached to the rotating disk, the beams do not adapt to the motion of the spinning disk. Light emitted from a source located in a nonrevolving but moving frame, such as a laboratory frame, travels at a constant speed relative to this frame and is not affected by the source's state of motion. Whereas light engaged in rotary motion (whether the source and receiver partake of that motion or not) *appears* to travel at a speed other than c relative to both an observer aboard the spinning disk and an observer in the *fixed* laboratory.

Dufour & Prunier calculated that the fringe shift predicted by relativity theory was 10 times smaller than the fringe shift obtained, and concluded that relativity theory was in complete disagreement with the experimental results. P. Langevin was confounded by their experiments, and stated that either light speed was $c + \omega r$ in one direction and $c - \omega r$ in the other direction (where r is the radius of the light path), or the time aboard the spinning apparatus had to change by $\pm 2A\omega/c^2$ in either direction (Langevin, 1937).

The accuracy of Sagnac's original experiment was only 1 in 100. Macek & Davis (1963) carried out a Sagnac test using lasers on a rotating disk and confirmed the Sagnac effect to 1 in 10^{12} . Hasselbach and Nicklaus (1993) showed that rotating electron beams in a vacuum display a Sagnac phase shift.

Sagnac-type experiments have also been conducted on a planetary scale. Using the Global Positioning System (GPS) satellite relay system, electromagnetic signals have been found to travel at $c - v$ from west to east (i.e. in the direction of the earth's rotation) and at $c + v$ from east to west, with v being the earth's rotation velocity (Allan et al., 1985). Light travels at c in the earth-centered inertial nonrotating frame, but not relative to an observer or receiver revolving around that frame. Müller & Means (1994) contend that the average residual of 5 nanoseconds, which Allan et al. attributed to experimental uncertainties, is partly caused by solar and galactic Sagnac effects. In an experiment using a ring-laser fixed to the earth's surface, Bilger et al. (1995) confirmed, with a resolution of 1 in 10^{20} , that electromagnetic signals propagate faster westward than eastward.

When clock stations on earth are synchronized by the exchange of electromagnetic signals, a correction has to be made for the earth's rotation (i.e. the Sagnac effect). The authorities concerned apply the correction factor to "time", rather than admitting that it is the apparent speed of light that varies. Their pretense that this correction is "relativistic" is far-fetched; the Sagnac effect is a simple first-order effect (i.e. proportional to v/c) and directly contradicts Special Relativity (Kelly, 2001, 2005; Gift, 2017).

Several first-order interferometric experiments have been conducted to look for deviations from c when counter-propagating light beams travel through a glass fiber or air-core fiber undergoing uniform translational motion, with both the light source and detector moving with the cable (Wang et al., 2003, 2004; Wang, 2005; Wang & Hatch, 2005). The travel-time difference and phase shift were found to be proportional to both the total length and the speed of the moving fiber, whether the motion is circular or linear.

Wang et al. suggested that the Sagnac effect arises because of the motion of the receiver during propagation of the signal from transmitter to receiver, and that this is so regardless of whether that motion is in a curved or a straight path. However, this is not exactly what is happening in either the Sagnac experiment or their own experiment. In the original Sagnac experiment, there was co-motion of the source and receiver on a shared accelerated rotary frame; and, likewise, in the experiments of Wang et al. there is co-motion of the source and receiver while they share the same moving inertial frame. But, in both cases, that co-motion results in the shortening of the path length of the "forward"-moving beam (such that source and receiver appear to move towards each other) and the lengthening of the path of the counter-moving beam (such that source and receiver appear to move apart). The two Doppler-like effects that both experiments synthesize are objectively real since they are actually the result of the two light paths being effectively different in length (so that paths of different lengths are traversed in different times but at a constant value of c). There is no need to invoke any correlated length contraction or time dilation to explain the Sagnac effect. This is underlined by the fact that the effect is detected both when the source and receiver are located on the rotating

platform (i.e. in the accelerated frame of rotation) and when they are located *outside* the rotating platform (i.e. in the inertial frame in which the axis of the rotating apparatus lies).

7.2 Michelson-Gale experiment

In 1925 Michelson and Gale carried out an experiment that demonstrated the earth's rotation by means of the Sagnac effect. They compared the phase difference between two beams of light traveling in opposite directions around a rectangular 1,829 m path of a stationary interferometer fixed to the surface of the rotating earth. They observed fringe shifts ranging from +0.55 to -0.05; the average displacement was 0.230, very close to the value of 0.236 which the earth's rotation was expected to produce at that latitude (Michelson, 1925; Michelson & Gale, 1925). The result has since been repeated with much higher resolution, e.g. using neutron interferometry (Staudenmann et al., 1980).

In an MM-type experiment, Brillet & Hall (1979) detected a "persistent and spurious" 17 Hz signal (at the second harmonic of table rotation). Aspden (1981, 1982) argued that this signal, when divided by the 8.85×10^{13} Hz laser frequency, is equal to $0.131(v/c)^2$. This yields $v = 363$ m/s, slightly higher than the earth's 355 m/s rotation speed at the relevant latitude. Aspden added that it would be inappropriate to speculate further, as the signal measured was very small and his theoretical treatment might not be wholly applicable. In a repeat of the 1932 Kennedy-Thorndike test, Hils & Hall (1990) also detected a once-per day effect due to earth's rotation.

The Sagnac and Michelson-Gale experiments can be interpreted as being consistent with the notions of absolute (aetherless) space or a fixed aether (filling all space), yet do not provide proof of either. The Michelson-Gale experiment contradicts the hypothesis of complete aether drag (Michelson, 1904); this hypothesis was used to explain the null result of the 1887 Michelson-Morley experiment, which was incompatible with the existence of a stationary aether. The Michelson-Gale experiment can also be interpreted as consistent with a rotating aethersphere surrounding the earth if it is assumed that the aether's rotation does not significantly affect the speed of light. Light generated on earth travels with the earth on its orbit around the sun, but does not adopt the daily spin of the earth on its axis.

The Michelson-Gale experiment was quickly accepted by the relativists, whereas the Sagnac effect was initially ignored and scorned by them, but is now universally accepted, as it is the fundamental design principle of ring-laser and fiber-optic gyroscopes, which are widely used in navigation systems. Einstein never mentioned the Sagnac and Michelson-Gale experiments in his publications, and even today many standard texts on Einstein's theories deal only cursorily with these experiments, or ignore them altogether.

Some relativists argue that the Sagnac effect is fully compatible with Special Relativity, while others say that SR has nothing to do with the Sagnac effect because SR applies solely to uniform straight-line motion and not to rotating reference frames. By focusing on inertia and translation and ignoring gravity and rotation, SR artificially separated translation and rotation. It argued that the former, in being uniform, was not accelerated, and that the latter was of

necessity accelerated. However, give that a perfectly straight trajectory is impossible, some degree of acceleration must always be involved, just as in the case of uniform rotation. Aetherometry goes a step further: it rejects the Newtonian assumption that a body not acted upon by an external force will, of its own accord, continue moving at a constant velocity, and argues that constant motion always requires a constant supply of energy and therefore constant acceleration (Correa & Correa, 2004).

Likewise, the earth's translation "around the sun" is no less an angular motion than is the earth's rotation. Moreover, other than at the axial poles, there is no frame of reference anywhere on the earth's surface that provides a nonaccelerated frame of reference. One may claim that light adapts to the earth's axis of rotation, or instead to the sun's axis of rotation, but such propositions are spurious if light is always adapted to the frame of its emitter, whatever its state or states of motion. The Wang et al. experiments appear to suggest that there is a Sagnac effect if the co-moving source and receiver travel on a straight line. However, they effectively set two light beams of different lengths in motion along some longitude on the earth's surface, thus forming the two longitudinal light segments of a short-distance planetary Sagnac experiment.

Those who use General Relativity to explain the Sagnac and Michelson-Gale experiments, invoke gravitational potentials, "time dilation", and the "dragging of spacetime" in the neighborhood of a rotating body (the Lense-Thirring effect). These explanations are needlessly complex and abstruse (Correa & Correa, 2001; Kelly, 2001, 2005). It is ironic that the relativists, who opposed the notion of a dragged aether, ended up believing in the dragging of "spacetime" – an irrational mathematical abstraction in which time is treated as a negative dimension of space!

The speed of sound is independent of the speed of the source or that of the receiver, because sound is referenced to a physical medium where sound waves propagate longitudinally with a constant velocity. It follows that for the same relative motion of a source and a receiver, the Doppler shift is quantitatively different according to whether the source, the receiver, or both are moving. According to Aetherometry (see Part 3), the speed of light is not referenced to a medium, but always to the motion of its emitter, light beams being composed of photons emitted by a sequence of decelerating matter particles that collectively transmit the light signal. That is why the linear Doppler effect for light only depends on the relative motion of a source and a receiver, i.e. on whether they approach or recede from each other. In the Sagnac experiment, source and receiver are co-moving (whether in the revolving frame or outside it), so it is only the light beams that have effectively different lengths. Accordingly, the experiment measures the rotary speed of the apparatus, since the velocity apparently added to, or subtracted from, c only appears at the receiver. In the rotating frame of the light source (and of every photon emitter along the light path), the velocity of light remains constant.

Part 3 of this article will further explore the conflicting interpretations of the conflicted results obtained from the various "aether-drift" experiments described in Parts 1 and 2.

REFERENCES

- Allan, D.W., et al. (1985). Around the world relativistic Sagnac experiment. *Science*, v. 228, p. 69-70.
- Aspden, H. (1981). Laser interferometry experiments on light speed anisotropy. *Physics Letters*, v. 85A, p. 411-414.
- Aspden, H. (1982). Mirror reflection effects in light speed anisotropy tests. *Speculations in Science and Technology*, v. 5, p. 421-431.
- Bilger, H.R., et al. (1995). Ring lasers for geodesy. *IEEE Transactions on Instrumentation and Measurement*, v. 44, no. 2, p. 468-470.
- Brillet, A., & Hall, J.L. (1979). Improved laser test of the isotropy of space. *Physical Review Letters*, v. 42, p. 549-552.
- Colladay, D., & Kostelecký, V.A. (1997). CPT violation and the standard model. *Physical Review D*, v. 55, no. 11, p. 6760-6774.
- Colladay, D., & Kostelecký, V.A. (1998). Lorentz-violating extension of the standard model. *Physical Review D*, v. 58, no. 11, 116002.
- Correa, P.N., & Correa, A.N. (2001). The Sagnac and Michelson-Gale-Pearson experiments: the tribulations of general relativity with respect to rotation. *Infinite Energy*, v. 7. no. 39, p. 32-49, ABRI monograph AS4-02, aetherometry.com/publications/direct/AToS/AS3-I.2.pdf.
- Correa, P.N., & Correa, A.N. (2004). The gravitational aether, Part II: Gravitational aetherometry (2), Mysteries of inertia. ABRI monograph AS3-II.4, AKRONOS Publishing.
- Correa, P.N., & Correa, A.N. (2008). Linear and angular light Doppler shifts and the Sagnac experiment: Aetherometry vs. Relativity (1). ABRI monograph AS3-I.3, AKRONOS Publishing.
- Correa, P.N., Correa, A.N., Askanas, M., Gryziecki, G., & Sola-Soler, J. (2008). A test of Aetherometry vs Relativity, Special and Larmor-Lorentz: The 1938 Ives-Stilwell experiment – Aetherometry vs. Relativity (2). ABRI monograph AS3-I.4, AKRONOS Publishing.
- Correa, P.N., Correa, A.N., Pratt, D., & Askanas, M. (2020). Re-examination of the experimental evidence for a nonzero aether drift. Part 1: Michelson-Morley-type experiments 1881-1930. *Journal of Aetherometric Research*, vol. 3, 1:1-41, aetherometry.com/publications/direct/JAethRes/JAR03-01-01.pdf.
- DeMeo, J. (2004). Dynamic and substantive cosmological ether. *Proceedings, Natural Philosophy Alliance*, v.1, no.1, <http://www.orgonelab.org/DynamicEther.pdf>.

Dufour, A., & Prunier, F. (1942). Sur un déplacement de franges enregistré sur une plate-forme en rotation uniforme. *Journal de Physique et le Radium*, 8th series, v. 3, no. 9, p. 153-162.

Galaev, Y.M. (2001). Etheral wind in experience of millimetric radiowaves propagation. *Spacetime & Substance*, v. 2, p. 211-225.

Galaev, Y.M. (2002). The measuring of ether-drift velocity and kinematic ether viscosity within optical waves band. *Spacetime & Substance*, v. 3, p. 207-224.

Gift, S.J.G. (2017). One-way speed of light using the Global Positioning System. www.researchgate.net.

Gurzadyan, V.G., & Margaryan, A.T. (2018). The light speed versus the observer: the Kennedy-Thorndike test from GRAAL-ESRF. *European Physical Journal C*, v. 78, 607.

Halliday, D., et al. (1992). *Physics* (vol. 2). New York: J. Wiley & Sons.

Hasselbach, F., & Nicklaus, M. (1993). Sagnac experiment with electrons: Observation of the rotational phase shift of electron waves in vacuum. *Physical Review A*, v. 48, no. 1, p. 143-151.

Hazelett, R., & Turner, D. (1979). *The Einstein Myth and the Ives Papers*. Old Greenwich: Devin Adair Co.

Hils, D., & Hall, J.L. (1990). Improved Kennedy-Thorndike experiment to test special relativity. *Physical Review Letters*, v. 64, no. 15, p. 1697-1700.

Ives, H.E., & Stilwell, G.R. (1938). An experimental study of the rate of a moving atomic clock. *Journal of the Optical Society of America*, v. 28, p. 215-226.

Jaseja, T.S., Javan, A., Murray, J., & Townes, C.H. (1964). Test of special relativity or of the isotropy of space by use of infrared masers. *Physical Review A*, v. 133, p. 1221-1225.

Kelly, A.G. (2001). Sagnac effect contradicts special relativity. *Infinite Energy*, v. 7, no. 39, p. 24-28.

Kelly, A. (2005). *Challenging Modern Physics: Questioning Einstein's relativity theories*. Boca Raton, FL: BrownWalker Press.

Kennedy, R.J., & Thorndike, E.M. (1932). Experimental establishment of the relativity of time. *Physical Review*, v. 42, p. 400-418.

Kostelecký, V.A. (2004). Gravity, Lorentz violation, and the standard model. *Physical Review D*, v. 69, no. 10, 105009.

Krisher, T.P., et al. (1990). Test of the isotropy of the one-way speed of light using hydrogen-maser frequency standards. *Physical Review D*, v. 42, p. 731-734.

Langevin, P. (1937). Relativité – Sur l'expérience de Sagnac. *Comptes Rendus*, v. 205, p. 304-306.

Nagel, M., et al. (2015). Direct terrestrial test of Lorentz symmetry in electrodynamics to 10^{-18} . *Nature Communications*, v. 6, 8174.

Macek, W.M., & Davis, D.T.M. (1963). Rotation rate sensing with traveling-wave ring lasers. *Applied Physics Letters*, v. 2, p. 67-68.

Mansouri, R., & Sexl, R.U. (1977). A test theory of special relativity. *General Relativity and Gravitation*, v. 8, no. 7, p. 497-513, p. 515-524, p. 809-814.

Marinov, S. (1980). Measurement of the laboratory's absolute velocity. *General Relativity and Gravitation*, v. 12, p. 57-66.

Marinov, S. (1987). A simplified repetition of Silvertooth's measurement of the absolute velocity of the solar system. In: J.P. Wesley (ed.), *Progress in Space Time Physics*, Blumberg: Benjamin Wesley, p. 16-31.

Marmet, P. (2005). Design error in the Brilliet and Hall's experiment. newtonphysics.on.ca/brillet-hall/index.html.

Michelson, A.A. (1904). Relative motion of earth and aether. *Philosophical Magazine*, v. 8, no. 48, p. 716-719.

Michelson, A.A. (1925). The effect of the earth's rotation on the velocity of light. Part I. *Astrophysical Journal*, v. 61, p. 137-139.

Michelson, A.A., & Gale, H. (1925). The effect of the earth's rotation on the velocity of light. Part II. *Astrophysical Journal*, v. 61, p. 140-145.

Michelson, A.A., Pease, F.G., & Pearson, F. (1929). Repetition of the Michelson-Morley experiment. *Journal of the Optical Society of America*, v. 18, p. 181-182.

Miller, D.C. (1926). Significance of the ether-drift experiments of 1925 at Mount Wilson. *Science*, v. 63, p. 433-443.

Müller, F.J., & Means, D. (1994). Solar and galactic Sagnac effects might be hidden in published GPS data of 1985. *Galilean Electrodynamics*, v. 5, no. 5, p. 90-97.

Müller, H., Herrmann, S., Braxmaier, C., Schiller, S., & Peters, A. (2003). Modern Michelson-Morley experiment using cryogenic optical resonators. *Physical Review Letters*, v. 91, p. 20401-20404.

Múnera, H.A. (2006). Observation during 2004 of periodic fringe-shifts in an adialeptometric stationary Michelson-Morley experiment. *Electromagnetic Phenomena*, v. 6, no. 1 (16), p. 70-92.

Múnera, H.A. (2017). Absolute velocity of earth from our stationary Michelson-Morley-Miller experiment at CIF. Conference on Physical Interpretations of Relativity Theory, PIRT-2017, Bauman University, Moscow, www.researchgate.net.

Múnera H.A., Hernández-Deckers, D., Arenas, G., & Alfonso, E. (2007). Observation of a significant influence of earth's motion on the velocity of photons in our terrestrial laboratory. Proceedings SPIE. 6664, *The Nature of Light: What Are Photons?*, 66640K.

Múnera H.A., Hernández-Deckers, D., Arenas, G., Alfonso, E., & López, I. (2009). Observation of a non-conventional influence of earth's motion on the velocity of photons, and calculation of the velocity of our galaxy. In: *Progress in Electromagnetics Research Symposium*, PIERS 2009, Beijing.

Planck Collaboration (2019). Planck 2018 results. I. Overview, and the cosmological legacy of Planck. *Astronomy & Astrophysics*, in press, [aanda.org/articles/aa/pdf/forth/aa33880-18.pdf](https://arxiv.org/abs/1907.12875).

Post, E.J. (1967). Sagnac effect. *Reviews of Modern Physics*, v. 39, no. 2, p. 475-493.

Reinhardt, S., et al. (2007). Test of relativistic time dilation with fast optical atomic clocks at different velocities. *Nature Physics*, v. 3, p. 861-864.

Riis, E., et al. (1988). Test of the isotropy of the speed of light using fast-beam laser spectroscopy. *Physical Review Letters*, v. 60, p. 81-84.

Riis, E., et al. (1994). Lamb shifts and hyperfine structure in ${}^6\text{Li}^+$ and ${}^7\text{Li}^+$: theory and experiment. *Physical Review A*, v. 49, no. 1, p. 207-220.

Roberts, T. (2007). What is the experimental basis of Special Relativity? www.desy.de/user/projects/Physics/Relativity/SR/experiments.html.

Robertson, H.P. (1949). Postulate versus observation in the Special Theory of Relativity. *Reviews of Modern Physics*, v. 21, no. 3, p. 378-382.

Rong, H., et al. (1998). A new precise value of the absolute 2^3S_1 , $F=5/2-2^3\text{P}_2$, $F=7/2$ transition frequency in ${}^7\text{Li}^+$. *European Physical Journal D*, v. 3, no. 3, p. 217-222.

Saathof, G., et al. (2003). Improved test of time dilation in Special Relativity. *Physical Review Letters*, v. 91, no. 19, 190403.

Sagnac, M.G. (1913a). L'éther lumineux démontré par l'effet du vent relatif d'éther dans un interféromètre en rotation uniforme. *Comptes Rendus*, v. 157, p. 708-710. (Translation: Hazelett & Turner, 1979, p. 247-248.)

Sagnac, M.G. (1913b). Sur la preuve de la réalité de l'éther lumineux par l'expérience de l'interféromètre tournant. *Comptes Rendus*, v. 157, p. 1410-1413. (Translation: Hazelett & Turner, 1979, p. 249-250.)

Sagnac, G. (2014). Effet tourbillonnaire optique. La circulation de l'éther lumineux dans un interféromètre tournant. *Journal de Physique Théorique et Appliquée*, v. 4, no. 1, p. 177-195.

Silvertooth, E.W. (1987). Experimental detection of the ether. *Speculations in Science and Technology*, v. 10, no. 3, p. 3-7.

Silvertooth, E.W. (1989). Motion through the ether. *Electronics and Wireless World*, no. 96, p. 437-438.

Silvertooth, E.W., & Whitney, C.K. (1992). A new Michelson Morley experiment. *Physics Essays*, v. 5, p. 82-89.

Staudenmann, J.-L., Werner, S.A., Colella, R., & Overhauser, A.W. (1980). Gravity and inertia in quantum mechanics. *Physical Review A*, v. 21, p. 1419-1438.

Wang, R. (2005). First-order fiber-interferometric experiments for crucial test of light-speed constancy. *Galilean Electrodynamics*, v. 16, no. 2, p. 23-30.

Wang, R., & Hatch, R.R. (2005). Conducting a crucial experiment of the constancy of the speed of light using GPS. *Infinite Energy*, v. 11, no. 64, p. 11-19.

Wang, R., Zheng, Y., Yao, A., & Langley, D. (2003). Modified Sagnac experiment for measuring travel-time difference between counter-propagating light beams in a uniformly moving fiber. *Physics Letters A*, v. 312, p. 7-10.

Wang, R., Zheng, Y., & Yao, A. (2004). Generalized Sagnac effect. *Physical Review Letters*, v. 93, p. 143901-1 - 143901-3.

Wesley, J.P. (1987a). Silvertooth's standing-wave measurement of absolute velocity of solar system. In: J.P. Wesley (ed.), *Progress in Space Time Physics*, Blumberg: Benjamin Wesley, p. 11-15.

Wesley, J.P. (1987b). Michelson-Morley result, a Voigt-Doppler effect in absolute space-time. In: J.P. Wesley (ed.), *Progress in Space Time Physics*, Blumberg: Benjamin Wesley, p. 96-103.

Wolf, P., & Petit, G. (1997). Satellite test of special relativity using the global positioning system. *Physical Review A*, v. 56, p. 4405-4409.